

	БЪЛГАРСКИ СТАНДАРТ	БДС EN 50281-3
ICS 29.260.20	СЪОРЪЖЕНИЯ ЗА ИЗПОЛЗВАНЕ ПРИ НАЛИЧИЕ НА ГОРИМ ПРАХ. Част 3: Класификация на зони, където има или може да се появи горим прах	
	<p>Българският стандарт БДС EN 50281-3 е одобрен от председателя на Българския институт по стандартизация на 2003-12-02.</p> <p>Европейският стандарт EN 50281-3:2002 е въведен чрез потвърждаване за прилагане като български стандарт.</p> <p style="text-align: center;">БДС EN 50281-3:2003 се разпространява с разрешението на CEN.</p> <p style="text-align: center;">This national document is distributed with the permission of</p> <p style="text-align: center;">CEN, rue de Stassart, 36 1050 Bruxelles, Belgium</p>	

000-0011726-2

Национален № за позоваване БДС EN 50281-3:2003

© БИС 2003

**Българските стандарти се разпространяват само от Българския институт по стандартизация
1797 София, кв. "Изгрев", ул. "165" № 3А**

НАЦИОНАЛЕН ПРЕДГОВОР

Този стандарт е приет за въвеждане чрез потвърждаване за прилагане като български стандарт от работна група.

Следват 24 страници на EN 50281-3:2002.

EUROPEAN STANDARD

EN 50281-3

NORME EUROPÉENNE

EUROPÄISCHE NORM

September 2002

ICS 29.100.01

English version

**Equipment for use in the presence of combustible dust
Part 3: Classification of areas where combustible dusts
are or may be present**

Appareils pour utilisation en présence
de poussières combustibles
Partie 3: Classement des emplacements
où des poussières combustibles sont
ou peuvent être présentes

Betriebsmittel zur Verwendung in
Bereichen mit brennbarem Staub
Teil 3: Einteilung von
staubexplosionsgefährdeten Bereichen

This European Standard was approved by CENELEC on 2002-03-05. CENELEC members are bound to comply with the CEN/CENELEC Internal Regulations which stipulate the conditions for giving this European Standard the status of a national standard without any alteration.

Up-to-date lists and bibliographical references concerning such national standards may be obtained on application to the Central Secretariat or to any CENELEC member.

This European Standard exists in three official versions (English, French, German). A version in any other language made by translation under the responsibility of a CENELEC member into its own language and notified to the Central Secretariat has the same status as the official versions.

CENELEC members are the national electrotechnical committees of Austria, Belgium, Czech Republic, Denmark, Finland, France, Germany, Greece, Hungary, Iceland, Ireland, Italy, Luxembourg, Malta, Netherlands, Norway, Portugal, Slovakia, Spain, Sweden, Switzerland and United Kingdom.

CENELEC

European Committee for Electrotechnical Standardization
Comité Européen de Normalisation Electrotechnique
Europäisches Komitee für Elektrotechnische Normung

Central Secretariat: rue de Stassart 35, B - 1050 Brussels

© 2002 CENELEC - All rights of exploitation in any form and by any means reserved worldwide for CENELEC members.

Ref. No. EN 50281-3:2002 E

Foreword

This European Standard was prepared by a joint Working Group (JWG 17) from CENELEC TC 31, Electrical apparatus for explosive atmospheres - General requirements, and CEN TC 305.

The text of the draft was submitted to the Unique Acceptance Procedure and was approved by CENELEC as EN 50281-3 on 2002-03-05.

This European Standard was prepared under a mandate given to CENELEC by the European Commission and the European Free Trade Association and supports the essential safety requirements of the EC Directive 94/9/EC.

The following dates were fixed:

- latest date by which the EN has to be implemented
at national level by publication of an identical
national standard or by endorsement (dop) 2003-03-01
- latest date by which the national standards conflicting
with the EN have to be withdrawn (dow) 2005-03-01

Annexes designated "informative" are given for information only.
In this standard, annexes A to C are informative.

Contents

Introduction	4
1 Scope	5
2 Normative references	5
3 Definitions	6
4 Area classification for combustible dusts	7
5 Sources of release for explosive dust atmospheres	9
6 Zones for explosive dust atmospheres	10
7 Dust layer hazard	13
8 Documentation	13
Annex A (informative) Examples of area classification	16
Annex B (informative) Risk of fire from hot surface ignition of dust layer	20
Annex C (informative) Housekeeping	23
Figure 1 – Identification of zones on drawings	15
Figure A.1 – Area classification for a bag emptying station within a building and without exhaust ventilation	16
Figure A.2 – Area classification for a bag emptying station within a building and with exhaust ventilation	17
Figure A.3 – Area classification for cyclone and filter with clean outlet outside building	18
Figure A.4 – Area classification for a drum tipper within a building without exhaust ventilation	19
Figure B.1 – Reduction in the maximum permissible surface temperature of apparatus for increasing depth of dust layers	21
Table 1 - Designation of zones depending on presence of combustible dust	10

Introduction

Combustible dusts are hazardous because when they are dispersed in air by any means they form potentially explosive atmospheres. Further, layers of combustible dust may ignite and act as ignition sources for an explosive atmosphere.

Therefore, equipment placed in an environment where dust clouds can form should be dust ignition protected and have a surface temperature limitation below the temperature at which a dust cloud or layer will ignite.

This standard gives guidance on the identification of areas where hazards from combustible dust can arise. The purpose is to permit selection of appropriate equipment for use in such areas. General and special criteria are given, with examples, for the procedure used to identify areas.

By exercising ingenuity in the layout of equipment, it is frequently possible to locate much of the equipment in less hazardous or in non-hazardous locations and thus, to reduce the amount of special equipment required.

This standard contains an informative annex giving practical examples for classifying areas.

1 Scope

This standard is concerned with the classification of areas where explosive dust/air mixtures and combustible dust layers are present, in order to permit the proper selection of equipment for use in such areas.

In this standard, explosive dust atmospheres and combustible dust layers are treated separately. In Clause 4 area classification for explosive dusts clouds is described, with dust layers acting as one of the possible sources of release. In Clause 7 the hazard of dust layer ignition is described.

The standard assumes effective housekeeping based on a system of cleaning for the plant.

The principles of the standard can also be followed when combustible fibres or flyings may cause a hazard.

This standard is intended to be applied where there can be a risk due to the presence of explosive dust/air mixtures or combustible dust layers under normal atmospheric conditions. It does not apply to

- underground mining areas,
- areas where a risk can arise due to the presence of hybrid mixtures,
- dusts of explosives which do not require atmospheric oxygen for combustion, or to pyrophoric substances,
- catastrophic failures, which are beyond the concept of abnormality dealt with in this standard (see NOTE 1),
- any risk arising from an emission of flammable or toxic gas from the dust.

This standard does not take into account the effects of consequential damage following a fire or an explosion.

NOTE 1 Catastrophic failure in this context is applied, for example, to the rupture of a storage silo or a pneumatic conveyor.

NOTE 2 In any process plant, irrespective of size, there can be numerous sources of ignition apart from those associated with equipment. Appropriate precautions will be necessary to ensure safety in this context, but these are outside the scope of this standard.

2 Normative references

This European Standard incorporates by dated or undated reference, provisions from other publications. These normative references are cited at the appropriate places in the text and the publications are listed hereafter. For dated references, subsequent amendments to or revisions of any of these publications apply to this European Standard only when incorporated in it by amendment or revision. For undated references the latest edition of the publication referred to applies (including amendments).

- | | |
|--------------------------|---|
| EN 1127-1 | Explosive atmospheres - Explosion prevention and protection
Part 1: Basic concepts and methodology |
| EN 13237-1 ¹⁾ | Potentially explosive atmosphere – Terms and definitions for equipment and protective systems intended for use in potentially explosive atmospheres |
| EN 50281-1-1 | Electrical apparatus for use in the presence of combustible dust
Part 1-1: Electrical apparatus protected by enclosures - Construction and testing |

1) At draft stage.

- EN 50281-1-2 Electrical apparatus for use in the presence of combustible dust
Part 1-2: Electrical apparatus protected by enclosures - Selection, installation and maintenance
- EN 50281-2-1 Electrical apparatus for use in the presence of combustible dust
Part 2-1: Test methods - Methods for determining the minimum ignition temperatures of dust
- IEC 61241-3 Electrical apparatus for use in the presence of combustible dust
Part 3: Classification of areas where combustible dusts are or may be present.
- ISO 4225 Air quality - General aspects – Vocabulary

3 Definitions

For the purpose of this standard the following definitions apply.

3.1

area

a three-dimensional region or space

3.2

atmospheric conditions (surrounding conditions)

conditions that include variations in pressure and temperature above and below reference levels of 101,3 kPa (1 013 mbar) and 20 °C (293 K), provided that the variations have a negligible effect on the explosive properties of the combustible dust (IEC 61241-3)

3.3

hybrid mixture

mixture of flammable substances in different physical states, with air (EN 1127-1)

NOTE An example of a hybrid mixture is a mixture of methane, coal dust and air.

3.4

dust

small solid particles including fibres and flyings in the atmosphere which settle out under their own weight, but which may remain suspended in air for some time (includes dust and grit as defined in ISO 4225)

3.5

explosive dust atmosphere

a mixture with air, under atmospheric conditions, of flammable substances in the form of dust or fibres in which, after ignition, combustion spreads throughout the unconsumed mixture (IEV 426-02-04)

3.6

combustible dust

dust that can burn or glow in air and could form explosive mixtures with air at atmospheric pressure and normal temperatures

3.7

hazardous area (dust)

area in which combustible dust in cloud form is, or can be expected to be, present in quantities such as to require special precautions for the construction, installation and use of equipment in order to prevent ignition of an explosive dust/air mixture. Hazardous areas are divided into zones based upon the frequency and duration of the occurrence of explosive dust/air mixture

3.8

non-hazardous area (dust)

area in which combustible dust in cloud form is not expected to be present in quantities such as to require special precautions for the construction, installation and use of apparatus

3.9

dust containment

those parts of the process equipment inside which materials are handled, processed, transported or stored e.g. to prevent the release of dust to the surrounding atmosphere

3.10

source of dust release

a point or location from which combustible dust can be released to the atmosphere. This can be either from a dust containment or a dust layer.

Sources of release will be divided into the following grades depending on the order of decreasing severity:

- continuous formation of a dust cloud: Locations in which a dust cloud may exist continuously, or may be expected to continue for long periods or for short periods which occur frequently;
- primary grade of release: A source can be expected to release combustible dust in normal operation occasionally;
- secondary grade of release: A source which is not expected to release combustible dust during normal operation but if it releases, is likely to do so only infrequently and for short periods only

3.11

extent of zone

distance in any direction from the edge of a source of release to the point where the hazard associated with the release is considered to exist no longer

3.12

normal operation

the situation when the process equipment is operating within its design parameters. Minor releases of dust which may form a cloud or layer (e.g. releases from filters) can be part of normal operation

3.13

abnormal operation

expected process linked malfunctions that can occur infrequently

3.14

equipment

machines, apparatus, fixed or mobile devices, control components and instrumentation thereof and detection or prevention systems which, separately or jointly, are intended for the generation, transfer, storage, measurement, control and conversion of energy or the processing of material and which are capable of causing an explosion through their own potential sources of ignition

4 Area classification for combustible dusts

4.1 General

This standard adopts the concept, similar to that used for flammable gases and vapours, of using area classification to give an assessment of the risk of fire and/or explosion from dust clouds.

Hazardous and non hazardous areas are defined in 3.7 and 3.8, respectively.

Combustible dusts form explosive atmospheres only at concentrations in the explosion range. Although a cloud with a very high concentration may not be explosive, however the danger exists that should the concentration fall, it may enter the explosion range. Depending on the circumstances, not every source of release will necessarily produce an explosive dust/air mixture.

Dusts which are not removed by mechanical extraction ventilation settle out, at a rate depending on among other things particle size, into layers or accumulations. It has to be taken into account that a dilute or small continuous source of release in time is able to produce a potentially hazardous dust layer.

The hazards presented by combustible dusts are

- the formation of a dust cloud from any source of release including a layer or accumulation to form an explosive atmosphere (see clause 5),
- the formation of dust layers which are not likely to form a dust cloud but which may ignite due to self heating or hot surfaces and cause a fire hazard or over heating of equipment. The ignited layer may also act as an ignition source for an explosive atmosphere (see clause 7).

Explosive dust clouds and combustible dust layer may exist therefore sources of ignition should be avoided.

If this cannot be done, then measures should be taken to reduce the likelihood of combustible dust and/or ignition sources so that the likelihood of coincidence is so small as to be acceptable. In some cases, it can be necessary to employ some form of explosion protection such as explosion venting or explosion suppression.

In this standard, explosive dust atmospheres and ignitable dust layers are treated separately. In this clause area classification for explosive dust clouds is described, with dust layers acting as one of the possible sources of release. In clause 7 the hazard of dust layer ignition is described.

4.2 Area classification objectives for explosive dust atmospheres

In most practical situations where combustible dusts are present, it is difficult to ensure that an explosive dust/air mixture will never occur. It can also be difficult to ensure that equipment will never give rise to a source of ignition. Therefore, in situations where an explosive dust/air mixture has a high likelihood of occurring, reliance is placed on using equipment which is designed to have an extremely low likelihood of creating a source of ignition.

Conversely, where the likelihood of an explosive dust/air mixture occurring is lower, equipment constructed to a less rigorous specification can be used.

4.3 Area classification procedure for explosive dust atmospheres

Area classification is based on an informed input from a number of sources. The decision to area classify depends on whether the dust is combustible or not. Dust combustibility can be confirmed by laboratory tests. An understanding of the material characteristics to be used in the process is required and these should be obtained from a process specialist. Account has to be taken of the operating and maintenance regime for the plant including the housekeeping. Specialist engineering knowledge may also be necessary to provide information on the nature of releases from particular items of plant. Close co-operation is necessary from specialists in safety and equipment. The definitions for zones of risk deal only with the cloud risk.

- a) The first step is to identify the material characteristics, e.g. particle size, moisture content, cloud and layer minimum ignition temperature and the electrical resistivity.
- b) The second step is to identify where dust containment or sources of dust release can be present, as given in 5.2. It may be necessary to consult process line diagrams and drawings of plant layout. This step should include the identification of the possibility of the formation of dust layers as given in clause 7.

- c) The third step is to determine the likelihood that dust will be released from those sources and thus, the likelihood of explosive dust/air mixtures in various parts of the installation as given in 5.2.2

It is only after these steps that the zones can be identified and their extents defined. The decisions on the zone types and extents and the presence of dust layers has to be recorded on the area classification drawing. (The drawing is to be used subsequently as the basis for the selection of equipment).

The reasons for the decisions taken should be recorded in notes of the area classification study to facilitate understanding at future area classification reviews. Reviews of the area classification shall take place following changes to the process or changes to process materials or if dust escapes become more common due to deterioration of the plant. It may be appropriate to hold reviews on a periodic basis.

Because this standard is to cover a wide range of circumstances, no exact identification of necessary measures can be given for each individual case. It is important, therefore, that the recommended procedure should be carried out by personnel having knowledge of the principles of area classification, the process material used, the plant involved and its functioning.

5 Sources of release for explosive dust atmospheres

5.1 General

Explosive dust atmospheres are formed from sources of dust release. Sources of dust release are a point or location from which combustible dust can be released or raised, such that an explosive dust/air atmosphere can be formed. This includes layers of combustible dust capable of being dispersed to form a dust cloud. Depending on the circumstances, not every source of release will necessarily produce an explosive dust/air mixture. On the other hand a dilute or small continuous source of release in time can produce a potentially hazardous dust layer.

The types of sources of release are defined in 3.10.

5.2 Identification of sources of release

The conditions need to be identified in which process equipment, process steps or other actions that can be expected in plants, can form explosive dust/air mixtures or create combustible dust layers. It is necessary to consider separately the inside and outside of a dust containment.

5.2.1 Dust containment

Inside a dust containment dust is not released to the atmosphere but as part of the process continuous dust clouds may be formed. These may exist continuously or may be expected to continue for long periods or for short periods which occur frequently depending on the process cycle. The equipment should be studied for normal operation, abnormal operation and in the startup and shutdown condition so that the incidence of cloud and layer presence can be identified. Where thick layers are formed these should be noted (see clause 7 for dust layers).

5.2.2 Sources of release

Outside the dust containment many factors can influence the area classification. Where higher than atmospheric pressures are used within the dust containment (positive pressure pneumatic transfer) dust can easily be blown out of leaking equipment. In the case of negative pressure within the dust containment, the likelihood of formation of dusty areas outside the equipment is very low. Dust particle size, moisture content and where applicable transport velocity, dust extraction rate and fall height can influence release rate potential. Once the process potential for release is known, each source of release must be identified and its grade of release determined.

Grades of release are:

- primary grade of release: examples are the close vicinity around an open bag filling or emptying point;
- secondary grade of release: an example is a dust handling plant where deposits of dust are present outside.

The following items should not be regarded as sources of release during normal and abnormal operation:

- pressure vessels, the main structure of the shell including its closed nozzles and manholes;
- pipes, ducting and trunking without joints;
- valve glands and flanged joints, provided, in the design and construction adequate consideration has been given to the prevention of leakage of dust.

Based on the likelihood of the formation of potentially explosive dust/air mixtures the areas can be designated according to Table 1.

Table 1 - Designation of zones depending on presence of combustible dust

Presence of combustible dust	Resulting zone classification of area of dust clouds
Continuous presence of a dust cloud	20
Primary grade of release	21
Secondary grade of release	22
<p>NOTE 1 Some silos may be filled or emptied only infrequently, and the inside may then be classified as zone 21. Equipment inside the silo may be used only when the silo is being emptied or filled. Equipment selection should take account of the fact that the dust cloud is likely to be present while the equipment is in operation.</p> <p>NOTE 2 The rare event of a burst of a large container of dust may cause a deep layer to form. If any deep layer formed in this way is removed quickly or the equipment isolated, it may not be necessary to classify the area as zone 22.</p> <p>NOTE 3 Many products such as grain and sugar contain a small amount of dust mixed into a large amount of granular material. Equipment selection should take account of the risk that the coarse material can be overheated and start to burn, even if no dust explosion is possible at that location. Burning granular material may be transported on through a process, to create the risk of an explosion elsewhere.</p>	

6 Zones for explosive dust atmospheres

6.1 General

Areas classified for explosive dust atmospheres are divided into zones; based upon the frequency and duration of the occurrence of explosive dust/air atmospheres.

The classification of dust zones as given below are published in EN 1127-1 (see also Directive 99/92/EC).

6.2 Zones for dusts

Layers, deposits and heaps of combustible dust shall be considered as any other source, which can form an explosive atmosphere.

Zone 20

A place in which an explosive atmosphere in the form of a cloud of combustible dust in air is present continuously, or for long periods or frequently.

Zone 21

A place in which an explosive atmosphere in the form of a cloud of combustible dust in air is likely to occur in normal operation occasionally.

Zone 22

A place in which an explosive atmosphere in the form of a cloud of combustible dust in air is not likely to occur in normal operation but, if it does occur, will persist for a short period only.

6.3 Examples of zones for explosive dust atmospheres

Zone 20

Examples of locations that may give rise to zone 20:

- locations inside the dust containment:
hoppers, silos, etc., cyclones and filters;
- dust transport systems, except some parts of belt and chain conveyors, etc.;
- blenders, mills, dryers, bagging equipment, etc.

Zone 21

Examples of locations that may give rise to zone 21:

- areas outside dust containment and in the immediate vicinity of access doors subject to frequent removal or opening for operation purposes when internal explosive dust/air mixtures are present;
- areas outside dust containment in the proximity of filling and emptying points, feed belts, sampling points, truck dump stations, belt dump over points, etc. where no measures are employed to prevent the formation of explosive dust/air mixtures;
- areas outside dust containment where dust accumulates and where due to process operations the dust layer is likely to be disturbed and form explosive dust/air mixtures;
- areas inside dust containment where explosive dust clouds are likely to occur (but neither continuously, nor for long periods, nor frequently) as e.g. silos (if filled and/or emptied only occasionally) and the dirty side of filters if large self cleaning intervals are occurring.

Zone 22

Examples of locations that may give rise to zone 22:

- outlets from bag filter vents, because in the event of a malfunction there can be emission of explosive dust/air mixtures;
- locations near equipment that has to be opened at infrequent intervals or equipment that from experience can easily form leaks where, due to pressure above atmospheric, dust will be blow out: pneumatic equipment, flexible connections that can become damaged, etc.
- storage of bags containing dusty product. Failure of bags can occur during handling, causing dust leakage.
- areas that normally are classified as zone 21 can fall into zone 22 when measures are employed to prevent the formation of explosive dust/air mixtures. Such measures include exhaust ventilation. The measures should be used in the vicinity of (bag) filling and emptying points, feed belts, sampling points, truck dump stations, belt dump over points, etc.
- areas where controllable dust layers are formed that are likely to be raised into explosive dust/air mixtures. Only if the layer is removed by cleaning before hazardous dust/air mixtures can be formed, the area is designated non-hazardous.

6.4 Extent of zones for explosive dust atmospheres

The extent of a zone for explosive dust atmospheres is defined as the distance in any direction from the edge of a source of dust release to the point where the hazard associated with that zone is considered to exist no longer. Consideration should be given to the fact that fine dust can be carried upwards from a source of release by air movement within a building. Where the classification gives rise to small non-hazardous areas between hazardous areas the classification should be extended to the full area.

Zone 20

The extent of zone 20 is as follows:

- the inside of ducts, producing and handling equipment in which explosive dust/air mixtures are present continuously for long periods, or frequently;
- if an explosive dust/air mixture outside dust containment is continuously present, a zone 20 classification is required.

NOTE Conditions leading to a zone 20 are forbidden in working areas.

Zone 21

In most circumstances the extent of zone 21 can be defined by evaluating the sources of release in relation to the environment causing explosive dust/air mixtures.

The extent of zone 21 is as follows:

- the inside of some dust handling equipment in which an explosive dust/air mixture is likely to occur;
- the extent of the area outside the equipment, formed by a source of release, also depending upon several dust parameters, such as dust amounts, flow rate, particle size, and product moisture content. This zone should be of only small extent: usually, a distance of 1 m around the source of release is sufficient (with extension vertically downwards to the ground or to the level of a solid floor).In the case of areas outside buildings (open air) the boundary of zone 21 can be altered because of weather effects such as wind, rain, etc.;
- where the spread of dust is limited by mechanical structures (wall, etc.) their surfaces can be taken as the boundary of the zone;
- practical considerations can make it desirable for the whole area under consideration to be classified as zone 21.

NOTE If dust layers accumulate outside zone 21 then further classification may be required taking into account the extent of the layer and any disturbance of the layer which produces a cloud.

Zone 22

In most circumstances the extent of zone 22 can be defined by evaluating sources of release in relation to the environment causing the explosive dust/air mixtures.

The extent of an area formed by a source of release also depends upon several dust parameters such as dust amounts, flow rate, particle size, product moisture content: usually an area of width 1 m around the source of release is sufficient. In case of areas outside buildings (open air) the boundary of zone 22 can be altered because of weather effects such as wind, rain, etc.

- where the spread of dust is limited by mechanical structures (walls, etc.) their surfaces can be taken as the boundary of the zone;
- practical considerations can make it desirable for the whole area under consideration to be classified as zone 22.

A non-confined zone 21 (not limited by mechanical structures e.g. a vessel with open manhole) located inside, will always be surrounded by a zone 22.

NOTE If during area classification review dust layers are found to have accumulated outside the original zone 22, then the zone 22 has to be extended.

7 Dust layer hazard

Inside a dust containment where dusts are handled or processed, layers of dust of uncontrolled thickness often cannot be prevented because they are an integral part of the process.

In principle, the thickness of dust layers outside equipment can be limited. The limitation is by housekeeping and during the consideration of sources of release it is essential to agree the nature of the housekeeping arrangements for the plant with plant management. The effect of housekeeping on dust layers is discussed in Annex C. For example where the person responsible for the selection of equipment can expect the plant to be free from dust layers a maximum permissible layer depth of 5 mm on the surface would be acceptable (to take account of any short term interruption of the cleaning cycle).

The risk of fire from hot surface ignition of a dust layer and how the maximum permissible surface temperature of equipment should be selected to avoid ignition is discussed in Annex B.

8 Documentation

8.1 General

It is recommended that area classification is undertaken in such a way that the various steps, which lead to the final area classification, are properly documented.

All relevant information used shall be referred to. Examples of such information, or of a method used, would be:

- a) recommendations from relevant codes and standards;
- b) an assessment of dust dispersion from all sources of release;
- c) process parameters, which influence the formation of dust/air mixtures and dust layers.

The results of the area classification study and any subsequent alteration to it shall be placed on record.

Those properties, which are relevant to area classification of all process materials used on the plant, shall be listed. The information shall include e.g. ignition temperatures of clouds and layers, explosive limits, electrical resistivity, moisture content and particle size.

8.2 Drawings, data sheets and tables

Area classification documents should include plans and elevations, as appropriate, which show both the type and extent of zones, the extent of dust layers, the minimum ignition temperatures of dusts and hence the maximum permissible surface temperature of the equipment to be selected to avoid ignition.

The documents should also include other relevant information such as:

- a) the location and identification of sources of release. For large and complex plants or process areas, it may be helpful to itemise or number the sources of release so as to facilitate cross referencing between the area classification data sheets and the drawings;
- b) information about housekeeping and other preventative measures to obtain the classification made;
- c) methods for maintaining and regular reviewing of the classification and reviewing when process materials, methods and equipment change;
- d) distribution list of the classification;
- e) the reasons for the decisions taken to establish the extent of zones and the extent of dust layers.

The area classification symbols, which are shown in Figure 1, are the preferred ones, but alternatives may be used provided that they are clearly defined in the documents.

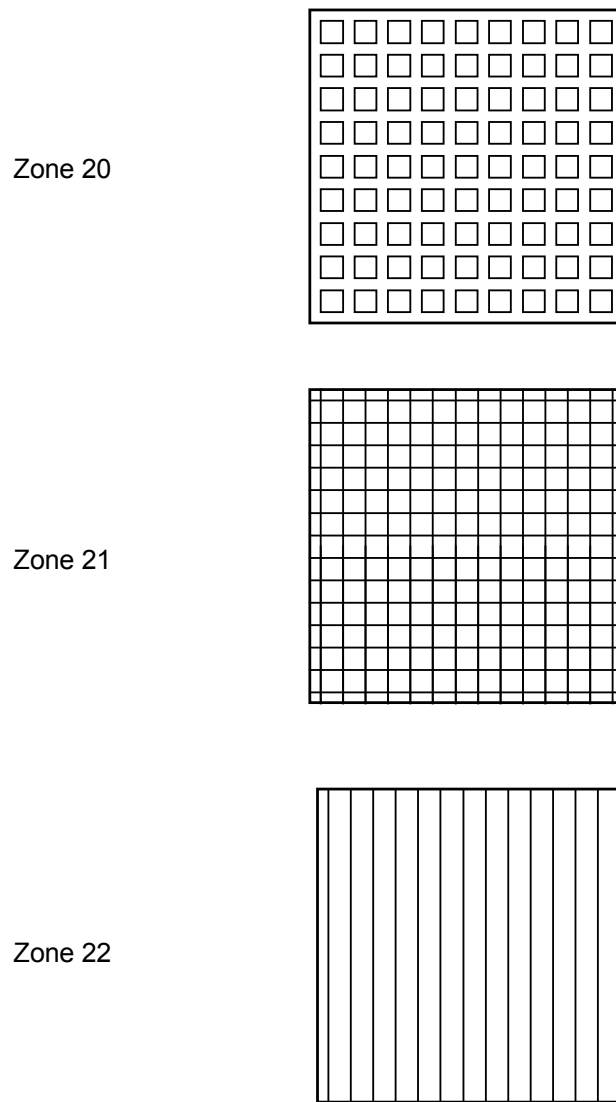

Figure 1 – Identification of zones on drawings

Annex A (informative)

Examples of area classification

A.1 Bag emptying station within a building and without exhaust ventilation

In this example bags are manually emptied frequently into a hopper from which the contents are conveyed pneumatically into some other part of the plant. Part of the hopper is always filled with product.

Zone 20 Inside the hopper because an explosive dust/air mixture is present frequently or even continuously.

Zone 21 The open manhole is a primary grade of release. Consequently, a zone 21 is defined around this manhole extending 1m from the edge of the manhole and extending down to the floor.

NOTE If dust layers accumulate then further classification may be required taking into account the extent of the layer and any disturbance of the layer which produces a cloud and the level of housekeeping (see Annex C). If air movements during the discharge of bags may occasionally carry the dust cloud beyond zone 21, an additional zone 22 is required.

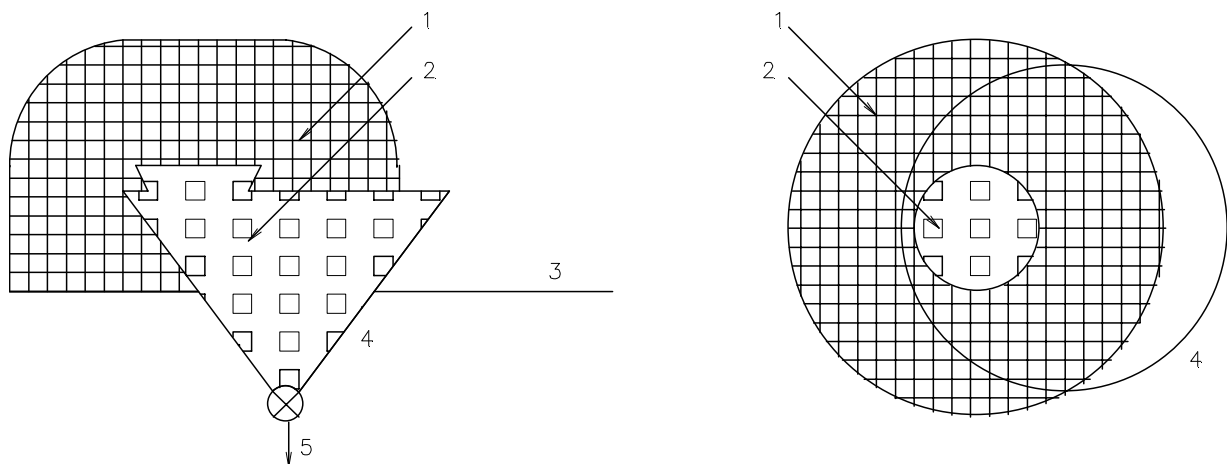

Key:

- 1) Zone 21 usually 1 m radius
- 2) Zone 20
- 3) Floor
- 4) Bag discharge hopper
- 5) To process

NOTE 1 The relative dimensions are for illustration only. In practice other distances may be required.

NOTE 2 Additional measures, such as explosion venting or explosion isolation etc., may be necessary but are outside the scope of this standard and are not, therefore, given.

**Figure A.1 - Area classification for a bag emptying station
within a building and without exhaust ventilation**

A.2 Bag emptying station within a building with exhaust ventilation

As example A.1, but in this case the system has exhaust ventilation. In this way the dust can be kept within the system as much as possible.

Zone 20 Inside the hopper because an explosive dust/air mixture is present frequently or even continuously.

Zone 22 The open manhole is a secondary grade of release. There is no escape of dust in normal circumstances because of the dust extraction system. In a well designed extraction system, any dust released will be sucked inside. Consequently, only a zone 22 is defined around this manhole extending 1 m from the edge of the manhole and extending down to the floor.

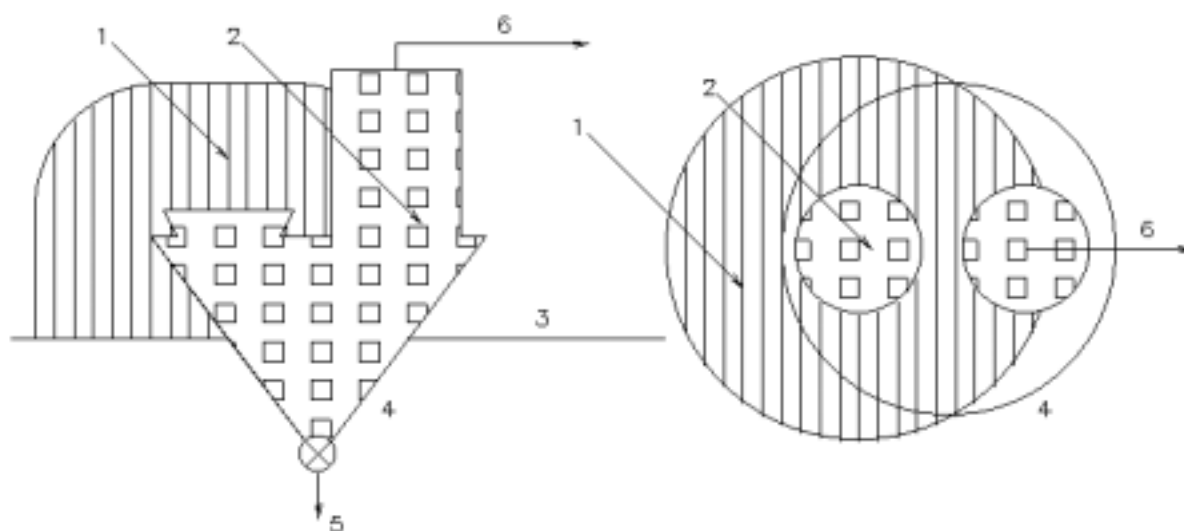

Key:

- 1) Zone 22 usually 1 m radius
- 2) Zone 20
- 3) Floor
- 4) Bag discharge hopper
- 5) To process
- 6) To extract within containment

NOTE 1 The relative dimensions are for illustration only. In practice other distances may be required.

NOTE 2 Additional measures, such as explosion venting or explosion isolation etc., may be necessary but are outside the scope of this standard and are not, therefore, given.

Figure A.2 - Area classification for a bag emptying station within a building and with exhaust ventilation

A.3 Cyclone and filter with clean outlet outside building

In this example the cyclone and filter are part of a suction extraction system. The extracted product passes via a continuously operating rotary valve and falls into a closed bin. The quantity of fines is very small and therefore the self-cleaning intervals are large, thus the interior contains a flammable cloud only occasionally during normal operation. The extraction fan on the filter unit blows the extracted air to the outside

Zone 20 Inside the cyclone only because an explosive dust/air mixture is present frequently or even continuously.

Zone 21 There is a zone 21 on the dirty side of the filter if only small quantities of dust are not collected by the cyclone in normal operation. If this is not the case the dirty side of the filter is zone 20.

Zone 22 The clean side of the filter may contain a flammable dust cloud if the filter element fails. This also applies to the extract ducting and around the discharge of the extract duct. The zone 22 extends 1 m around the outlet of the ducting and extends down to the ground (not shown in diagram).

NOTE If dust layers accumulate outside the plant equipment then further classification may be required taking into account the extent of the layer and any disturbance of the layer which produces a cloud. The effect of conditions outside may be taken into account. For example wind, rain or humidity may prevent layers of combustible dust accumulating.

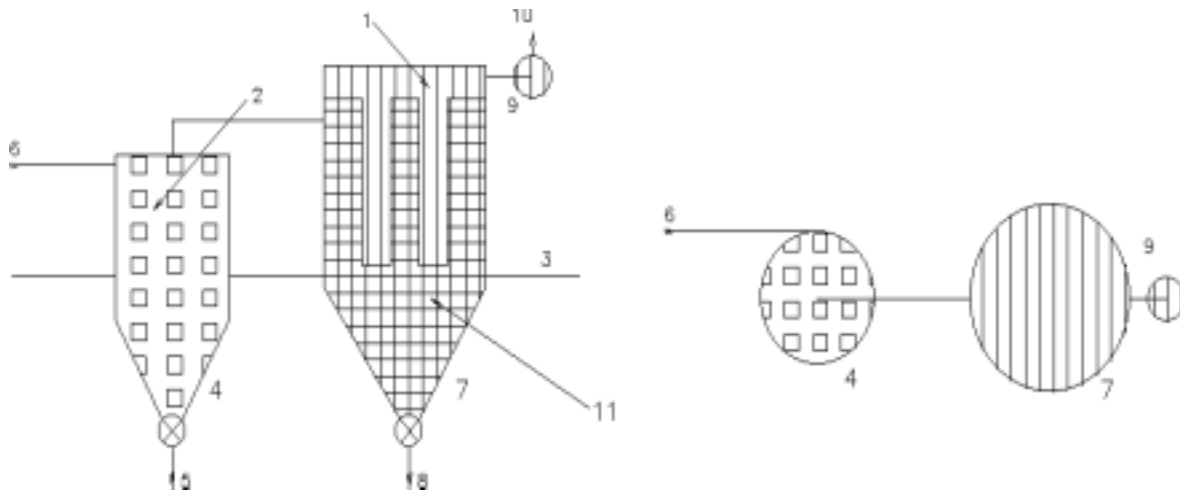

Key:

- | | | |
|------------|--------------------|----------------|
| 1) Zone 22 | 5) To product silo | 9) Extract fan |
| 2) Zone 20 | 6) Inlet | 10) To outlet |
| 3) Floor | 7) Filter | 11) Zone 21 |
| 4) Cyclone | 8) To fines bin | |

NOTE 1 The relative dimensions are for illustration only. In practice other distances may be required.

NOTE 2 Additional measures, such as explosion venting or explosion isolation etc., may be necessary but are outside the scope of this standard and are not, therefore, given.

Figure A.3 - Area classification for cyclone and filter with clean outlet outside building

A.4 Drum tipper within a building without exhaust ventilation

In this example powder in 200 litre drums is emptied into a hopper to be transported by screw conveyor to an adjacent room. A full drum is positioned on the platform and the lid removed. Hydraulic cylinders clamp the drum to the diaphragm valve which is closed. The hopper lid is opened and the drum carrier rotated to place the diaphragm valve on top of the hopper. The diaphragm valve is opened and powder is transported by the screw conveyor over a period of time until the drum is empty.

When a new drum is required the diaphragm valve is closed. The drum carrier is rotated back to its original position and the hopper lid is closed. The hydraulic cylinders release the drum and its lid is replaced before the drum is removed.

Zone 20 The interior of the drum, hopper and screw conveyor will contain dust clouds frequently and for long periods and are therefore classified zone 20.

Zone 21 Releases of dust in the form of a cloud occur when the lid of the drum and the lid of the hopper are removed and when the diaphragm valve is placed on or removed from the top of the hopper. Consequently zone 21 is defined for 1 m around the tops of the drum, hopper and around the diaphragm valve. These zones 21 extend to the floor.

Zone 22 The remainder of the room is zone 22 due to the possibility of accidental spillage and disturbance of large quantities of dust.

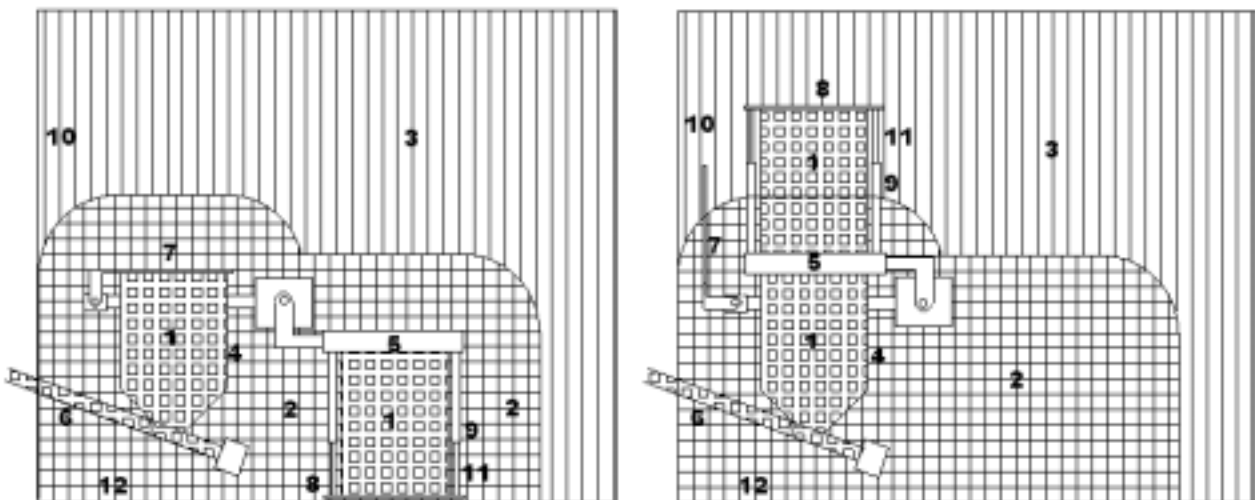

Key:

- | | | |
|------------|--------------------|------------------------|
| 1) Zone 20 | 5) Diaphragm valve | 9) Hydraulic cylinders |
| 2) Zone 21 | 6) Screw conveyor | 10) Wall |
| 3) Zone 22 | 7) Hopper lid | 11) Drum |
| 4) Hopper | 8) Drum platform | 12) Floor |

NOTE 1 The relative dimensions are for illustration only. In practice other distances may be required.

NOTE 2 Additional measures, such as explosion venting or explosion isolation etc., may be necessary but are outside the scope of this standard and are not, therefore, given.

Figure A.4 - Area classification for a drum tipper within a building without exhaust ventilation

Annex B (informative)

Risk of fire from hot surface ignition of dust layer

The risk of fire is based on the possibility that a layer of dust could act as an ignition source due to temperature exposure by hot surfaces or heat flux from equipment. The appropriate measure to control this risk is temperature limitation of surfaces in contact with dust layers or limiting the energy release from the equipment under consideration.

For application and installation details see EN 50281-1-2.

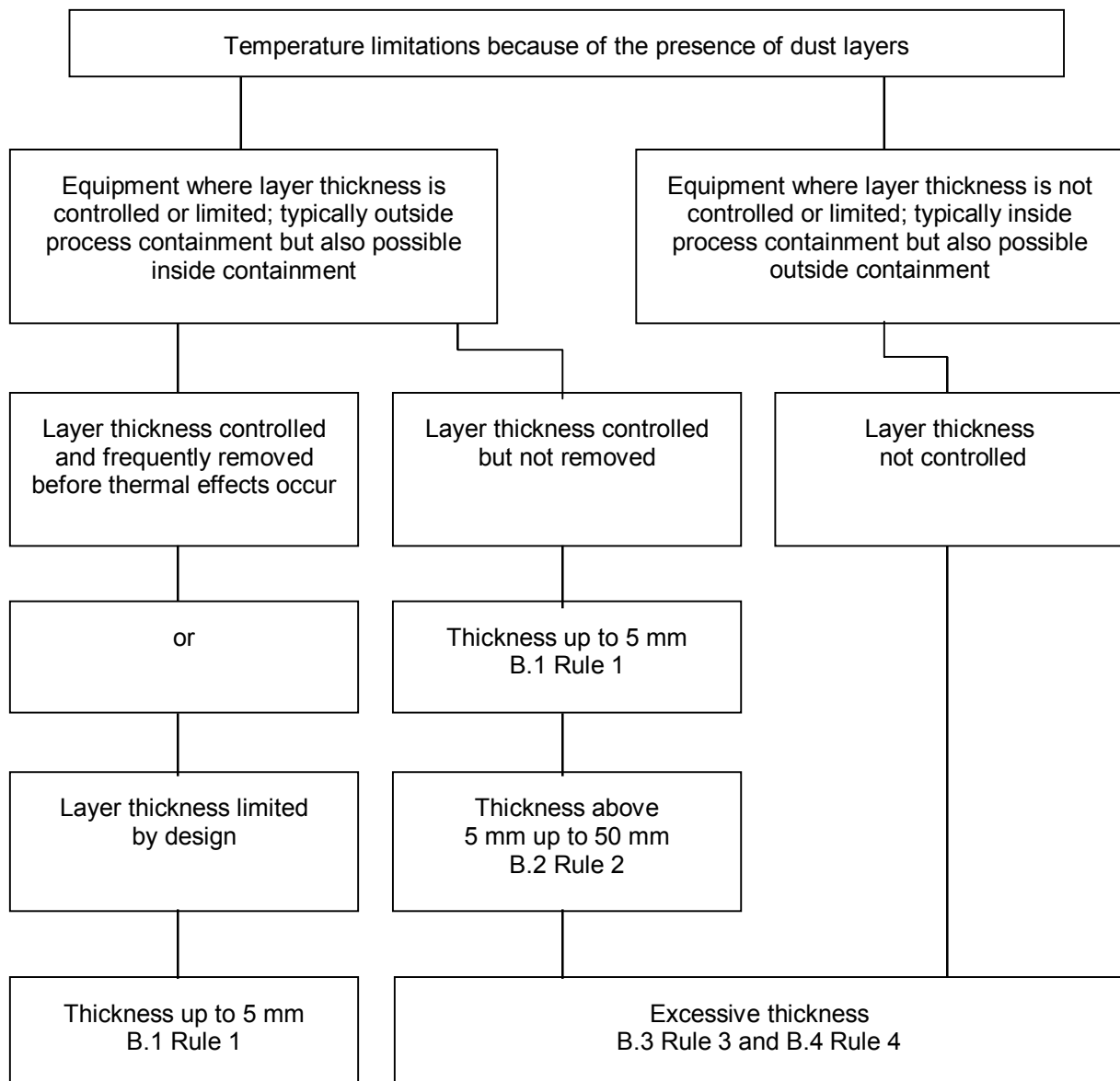

**B.1 Rule 1
Dust layers up to 5 mm**

The maximum surface temperature of the apparatus when tested in the dust-free test method in 10.1 of EN 50281-1-1 shall be equal to or less than the minimum ignition temperature for 5 mm layer thickness of the dust concerned reduced by a value of 75 K:

$$T_{\max} = T_{5\text{ mm}} - 75\text{ K}$$

$T_{5\text{ mm}}$ is the minimum ignition temperature of a 5 mm dust layer

Subclause 6.2.1 of EN 50281-1-2 applies.

**B.2 Rule 2
Dust layers above 5 mm up to 50 mm thickness**

Where dust layers in excess of 5 mm up to 50 mm may be formed on apparatus, the maximum permissible surface temperature must be reduced accordingly.

For guidance, examples of the reduction in maximum permissible surface temperature of apparatus used in the presence of dusts having minimum ignition temperatures equal to or above 250°C for a 5 mm layer are shown in Figure B.1 for increasing depth of layers.

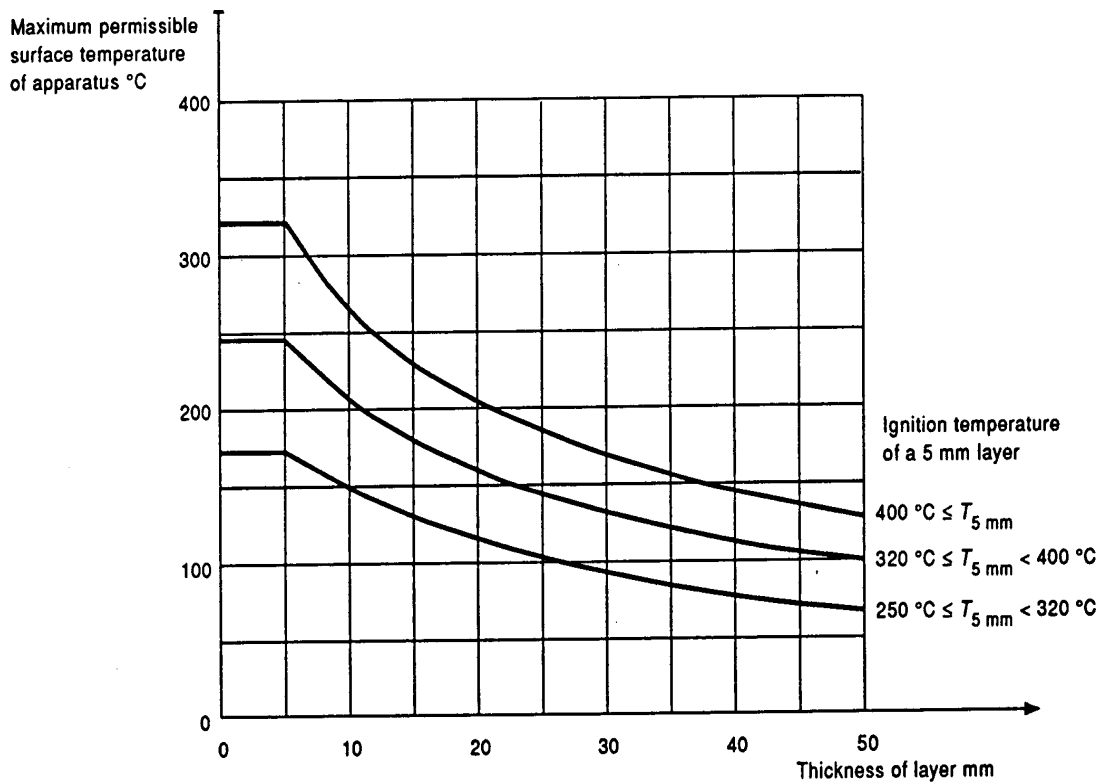

Figure B.1 - Reduction in the maximum permissible surface temperature of apparatus for increasing depth of dust layers

Laboratory investigation should be carried out to find the minimum ignition temperature as a dependence of dust layer thickness. Figure B.1 should be taken as a semi-quantitative guideline.

Subclauses 6.2.1 and 6.2.2 of EN 50281-1-2 apply.

B.3 Rule 3 Dust layers of excessive thickness

Where it cannot be avoided that a dust layer of excessive thickness be formed on top of an apparatus or around the sides of an apparatus, or where the apparatus is totally submerged in the dust, due to the insulation effect, a lower surface temperature limitation will apply based on the depth of the layer. This special requirement can be met by a system of power limitation, which could be determined experimentally under simulated working conditions, or evaluated using recognised calculation methods.

Apparatus for measurement and control techniques (e.g. instrumentation, sensors, controls) with very low energy are typical applications under dust layers of excessive thickness. Power engineering apparatus (such as motors, luminaires, plugs and sockets) should be avoided in such conditions, or if used at all, be submitted to special investigation.

Subclauses 6.2.1, 6.2.2 and 6.2.3 of EN 50281-1-2 apply.

B.4 Rule 4 Laboratory investigation

Laboratory tests shall be carried out for equipment and/or dust

- where the minimum ignition temperature of a 5 mm layer is below 250°C, or there is any doubt concerning the application of the graph in Rule 2,
- covered by dust layers in excess of 50 mm on their top section,
- with layers of any thickness greater than 5 mm formed around the sides of an apparatus,
- completely submerged in dust.

Laboratory investigation may include tests and/or recognised calculation schemes

Subclause 6.3 of EN 50281-1-2 applies.

Annex C (informative)

Housekeeping

C.1 Introduction

Area classification in this standard is based on definitions for zones, which do not specifically include consideration of layers. Any hazards presented by dust layers should be considered separately from dust clouds.

Three risks are presented by dust layers:

- 1) a primary explosion within a building may raise dust layers into clouds, and cause secondary explosions more damaging than the primary event. Dust layers should always be controlled to reduce this risk;
- 2) dust layers may be ignited by the heat flux from equipment on which the layer rests. The risk is of fire, rather than explosion, and this may be a slow process;
- 3) a dust layer may be raised into a cloud, ignite on a hot surface and cause an explosion. In practice, dust cloud ignition temperatures are often much higher than layer ignition temperatures. For example, lignite dust has a layer ignition temperature of 230°C - 250°C, but a cloud ignition temperature of 410°C - 450°C. Few types of equipment except combustion plant have surfaces as hot as this. There are very few examples of explosions started by a layer raised into a dust cloud outside a containment system.

These risks depend on the properties of the dust, and the thickness of layers, which is influenced by the nature of the housekeeping. The likelihood of a layer causing a fire can be controlled by the correct selection of equipment and effective housekeeping.

C.2 Levels of housekeeping

The frequency of cleaning alone is not enough to determine whether a layer contains sufficient dust to control these risks. The rate of deposition of the dust has an effect; for example, a secondary grade of release with a high deposition rate may create a dangerous layer much more quickly than a primary grade with a lower deposition rate. The effect of cleaning is therefore more important than frequency.

Thus the presence and duration of a dust layer depends on:

- the grade of release from the source of the dust,
- the rate at which dust is deposited,
- the effectiveness of housekeeping (cleaning).

Three levels of housekeeping can be described:

good: dust layers are kept to negligible thickness, or are non-existent, irrespective of the grade of release. In this case the risk of the occurrence of explosive dust clouds from layers and the risk of fire due to layers has been removed;

fair: dust layers are not negligible but are short lived (less than 1 shift). Depending on the thermal stability of the dust, and the surface temperature of the equipment, the dust may be removed before any fire can start. In this case equipment selected according to rule 1 in Annex B is likely to be suitable;

poor: dust layers are not negligible and persist for more than 1 shift. The fire risk may be significant, and this should be controlled by selecting equipment according to the advice in Annex B.

Poor housekeeping combined with conditions that can create a dust cloud from a layer in normal operation should be prevented. Poor housekeeping combined with conditions that can create a dust cloud during abnormal operation may give rise to an area of zone 22.

NOTE 1 When a planned level of housekeeping is not maintained, additional fire and explosion risks are created. Some equipment may no longer be suitable.

NOTE 2 Changes to the state of the dust layer e.g. moisture absorbency may make it impossible to raise the layer into a dust cloud. In this case, there may be no secondary explosion risk, but the risk of fire may remain the same.